



Aviation Devices & Electronic Components, L.L.C.  
1810 Mony Street  
Fort Worth, TX 76102

Document IS-AD27500-030  
Revision D  
Date: 08-23-06  
Page 1 of 3

Phone: 817-738-9161  
FAX: 817-738-9163

## **Installation Instruction IS-AD27500-030**

### **Av-DEC Connector Sealing Kit Self-Fusing Silicone Tape over StretchSeal Tape with Polyurethane Potting Compound**

**NOTE: Read this installation instruction completely before installation**

#### **1. SCOPE**

This instruction describes the method for installation of Av-DEC Connector Sealing Kit consisting of Av-DEC StretchSeal Tape (part number AD89503), Av-DEC Self Fusing Tape (part number AD59163) and Av-DEC Polyurethane Sealant (part number HT3326-5) for cold application on existing harnesses and components for moisture sealing and abrasion protection.

#### **2. APPLICABLE DOCUMENTS**

Aircraft maintenance manual, avionics installation manual, and/or user maintenance manual as applicable.

#### **3. REQUIREMENTS**

##### **3.1 MATERIALS.**

- 3.1.1 StretchSeal Tape-AD89503**
- 3.1.2 Self Fusing Tape-AD59163**
- 3.1.3 Potting Compound- HT3326-5**
- 3.1.4 Sealant Dispenser-Av-DEC PN UG981108-01 or equivalent**
- 3.1.5 Cleaning Solvent-Isopropyl alcohol or other approved cleaning solvent.**

**3.2 SURFACE PREPARATION.** Harness bundle and components that will come in contact with the Connector Sealing Kit shall be free of dirt, oil, grease, and other contamination prior to installation. Residue of previously applied adhesives or sealants shall be removed. Clean harness and components as required with clean cloth moistened with solvent. If possible, unmate the connector and orient the connector face in a downward position.

**3.3 PREPARATION OF POTTING COMPOUND-** Remove injectable polyurethane sealant from package. Load cartridge into sealant dispenser (PN UG981108-01 or equivalent) and follow package instructions for priming and dispensing potting compound (sealant).

##### **3.4 INSTALLATION OF STRETCHSEAL TAPE (AD89503) AND POTTING COMPOUND.**

**3.4.1** Remove the StretchSeal Tape from the package and unroll a small length of tape. Pull back a small amount of the release film, making sure that the tape remains free of dirt or other contaminants.

- 3.4.2** Begin wrapping the StretchSeal Tape around the connector to be protected, behind the coupling ring (nut). Stretch the tape 25 to 50% to ensure good compression around the connector body and rear accessories. (see figure 1)

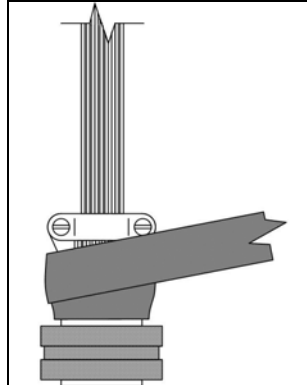

Figure 1

- 3.4.3** Continue to apply the StretchSeal Tape with a 50% overlap.
- 3.4.4** Stop wrapping the StretchSeal Tape and hold in place. Inject potting compound into the wire bundle immediately behind the connector rear accessory or through any openings in the rear accessory. (see figure 2)

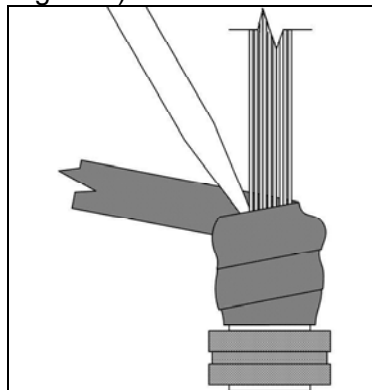

Figure 2

- 3.4.5** Alternate wrapping StretchSeal Tape and injecting potting compound until the connector rear accessory is covered and at least one complete wrap of StretchSeal Tape has been installed on the harness bundle.
- 3.4.6** Cut off any excess StretchSeal Tape. Follow instructions provided with potting compound for disposal. (see figure 3)

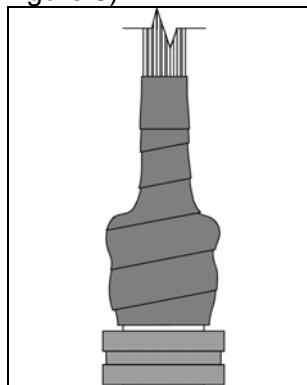

Figure 3

### 3.5 INSTALLATION OF SELF-FUSING SILICONE TAPE (AD59163) OVER STRETCHSEAL TAPE.

- 3.5.1 Remove Self-Fusing Silicone Tape from the package. Pull back a small amount of the release film, making sure that the tape remains free of dirt or other contaminants.
- 3.5.2 Begin to wrap the connector behind the coupling ring (nut) with one complete revolution on itself.
- 3.5.3 After the first full wrap is complete, continue wrapping with a 50% overlap over the top of the StretchSeal Tape. Use the line in the middle of Self-Fusing Silicone Tape as a guide and remove the release film as required. (see figure 4)

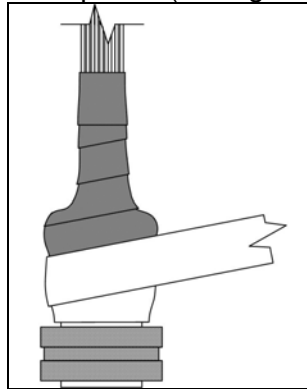

Figure 4

- 3.5.4 Stretch the Self-Fusing Silicone Tape 50 to 300% during application to ensure a tight fit when complete. Stretching the tape will aid in the fusing process.
- 3.5.5 Clean any excess potting compound (sealant) that may have been forced out of the StretchSeal Tape from the wire bundle.
- 3.5.6 Continue to wrap the Self-Fusing Silicone Tape until at least one complete wrap past the end of the StretchSeal Tape. Make one complete wrap over the top of the last wrap. The first and last wrap must always be a complete wrap directly over the top of the previous wrap.
- 3.5.7 Cut off any excess Self-Fusing Silicone Tape (see figure 5)

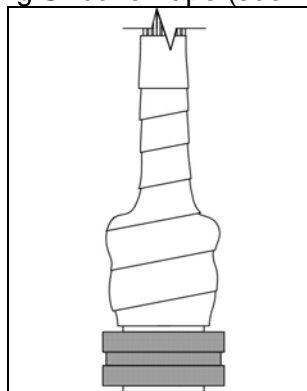

Figure 5

- 4 **MAINTENANCE.** No special maintenance procedures required.
- 5 **CONNECTOR SEALING KIT REMOVAL.** Cut the Self-Fusing Silicone Tape with a sharp blade or similar tool, taking care not to cut the harness beneath. Peel the tape away from the harness bundle. Remove the StretchSeal Tape. Remove the polyurethane sealant by pulling with fingers or other blunt instrument, so as not to damage with wires. Use isopropyl alcohol or other approved cleaning solvent to remove any remaining residue.