

---

## INSTALLATION INSTRUCTIONS

---

### Av-DEC® Connector Sealing Kit Av-DEC® Self-Fusing Silicone Tape over StretchSeal Tape

**NOTE: Read this installation instruction completely before installation**

#### 1. SCOPE

This instruction describes the method for installation of Av-DEC® StretchSeal™ Tape (part number AD89503) and Av-DEC® Self-Fusing Silicone Tape (part number AD59163) for cold application on existing harnesses and components for moisture sealing and abrasion protection.

#### 2. APPLICABLE DOCUMENTS

Aircraft maintenance manual, avionics installation manual, and/or user maintenance manual as applicable.

#### 3. REQUIREMENTS

##### 3.1 MATERIALS.

3.1.1 **StretchSeal™ Tape**-AD89503

3.1.2 **Self-Fusing Tape**-AD59163

3.1.3 **Cleaning Solvent**-Isopropyl alcohol or other approved cleaning solvent.

3.2 **SURFACE PREPARATION.** Harness bundle and components that will come in contact with the Connector Sealing Kit shall be free of dirt, oil, grease, and other contamination prior to installation. Residue of previously applied adhesives or sealants shall be removed. Clean harness and components as required with clean cloth moistened with solvent.

##### 3.3 INSTALLATION OF STRETCHSEAL™ TAPE (AD89503).

3.3.1 Remove the StretchSeal™ Tape from the package and unroll a small length of tape. Pull back a small amount of the release film, making sure that the tape remains free of dirt or other contaminants.

3.3.2 Begin wrapping the StretchSeal™ Tape around the connector to be protected, behind the coupling ring (nut). Stretch the tape 25 to 50% to ensure good compression around the connector body and rear accessories. Remove release film as required. (see figure 1)

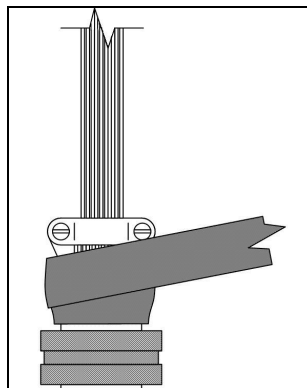

## INSTALLATION INSTRUCTIONS

Figure 1

- 3.3.3** Continue to apply the StretchSeal™ Tape with a 50% overlap until the connector rear accessory is covered and at least one complete wrap of StretchSeal™ Tape has been installed on the harness bundle. (see figure 2)

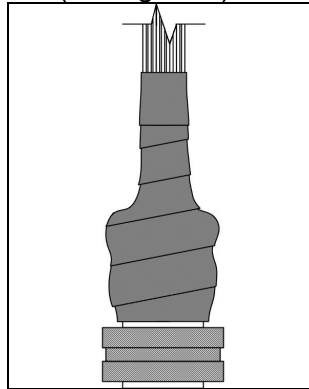

Figure 2

- 3.3.4** Cut off any excess StretchSeal™

### **3.4 INSTALLATION OF SELF-FUSING SILICONE TAPE (AD59163) OVER STRETCHSEAL™ TAPE.**

- 3.4.1** Remove Self-Fusing Silicone Tape from the package. Pull back a small amount of the release film, making sure that the tape remains free of dirt or other contaminants.
- 3.4.2** Begin to wrap the connector behind the coupling ring (nut) with one complete revolution on itself.
- 3.4.3** After the first full wrap is complete, continue wrapping with a 50% overlap over the top of the StretchSeal™ Tape. Use the line in the middle of Self-Fusing Silicone Tape as a guide and remove the release film as required. (see figure 3)

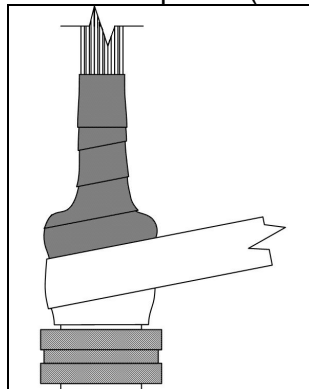

Figure 3

- 3.4.4** Stretch the Self-Fusing Silicone Tape 50 to 300% during application to ensure a tight fit when complete. Stretching the tape will aid in the fusing process.
- 3.4.5** Continue to wrap the Self-Fusing Silicone Tape until at least one complete wrap past the end of the StretchSeal™ Tape. Make one complete wrap over the top of the last wrap. The first and last wrap must always be a complete wrap directly over the top of the previous wrap.
- 3.4.6** Cut off any excess Self-Fusing Silicone Tape (see figure 4)

---

## INSTALLATION INSTRUCTIONS

---

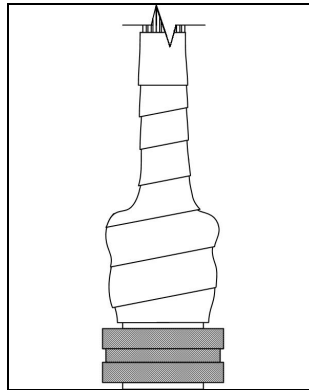

Figure 4

- 4 **MAINTENANCE.** No special maintenance procedures required.
- 5 **CONNECTOR SEALING KIT REMOVAL.** Cut the Self-Fusing Silicone Tape with an Exacto blade or similar tool, taking care not to cut the harness beneath. Peel the tape away from the harness bundle. Remove the StretchSeal™ Tape. Use isopropyl alcohol or other approved cleaning solvent to remove any remaining residue.

Dual Wrap  
Installation Video



Scan QR Code

